

# PROJECT LOCATIONS: I-894: 89<sup>th</sup> to 35<sup>th</sup> STREET; LOOMIS ROAD BRIDGE



**I-894/I-43/I-41 RESURFACING PROJECT**  
89TH STREET TO 35TH STREET



**WIS 36 RECONSTRUCTION PROJECT**  
LOOMIS ROAD BRIDGE OVER I-894



# ANTICIPATED CONSTRUCTION SCHEDULE

During construction, I-894 will remain open to traffic. However, lane and ramp closures will be necessary for crews to complete the work. More information will be shared as it becomes available.

- **Eastbound** – Through traffic will be reduced to two lanes for about two weeks, likely in late April.
- **Westbound** – Through traffic will be reduced to two lanes from (likely) mid-April to late-June.
- **84<sup>th</sup> Street** – Traffic will remain open during the nighttime hours, though lanes will be reduced frequently during these times.
- **68<sup>th</sup> Street** – Nighttime closures of the 68<sup>th</sup> Street bridge over the freeway in both directions will likely occur over several nights in late July or August.
- **51<sup>st</sup> Street** – A full closure of 51<sup>st</sup> Street in both directions (under the freeway) will occur for approximately two weeks this summer, likely in July or August.
- **Loomis Road** – A full closure of the Loomis Road bridge over the freeway in both directions will occur for an extended time, likely from mid-April to early November.
- **35<sup>th</sup> Street** – A full closure of the 35<sup>th</sup> Street bridge over the freeway in both directions will occur for 30 consecutive days in the summer, anticipated to start in later June or early July. Also, nighttime closures of the 35<sup>th</sup> Street bridge over I-41 in both directions will occur over several nights in late July or August.

**NOTE: 68<sup>th</sup> Street, 51<sup>st</sup> Street, and 35<sup>th</sup> Street night closures will not be allowed to occur concurrently.**



**I-894/I-43/I-41 RESURFACING PROJECT**

89TH STREET TO 35TH STREET

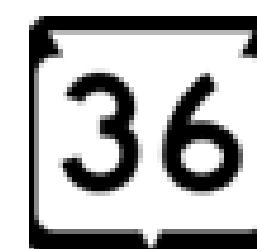

**WIS 36 RECONSTRUCTION PROJECT**

LOOMIS ROAD BRIDGE OVER I-894





# PAVEMENT COMPONENTS

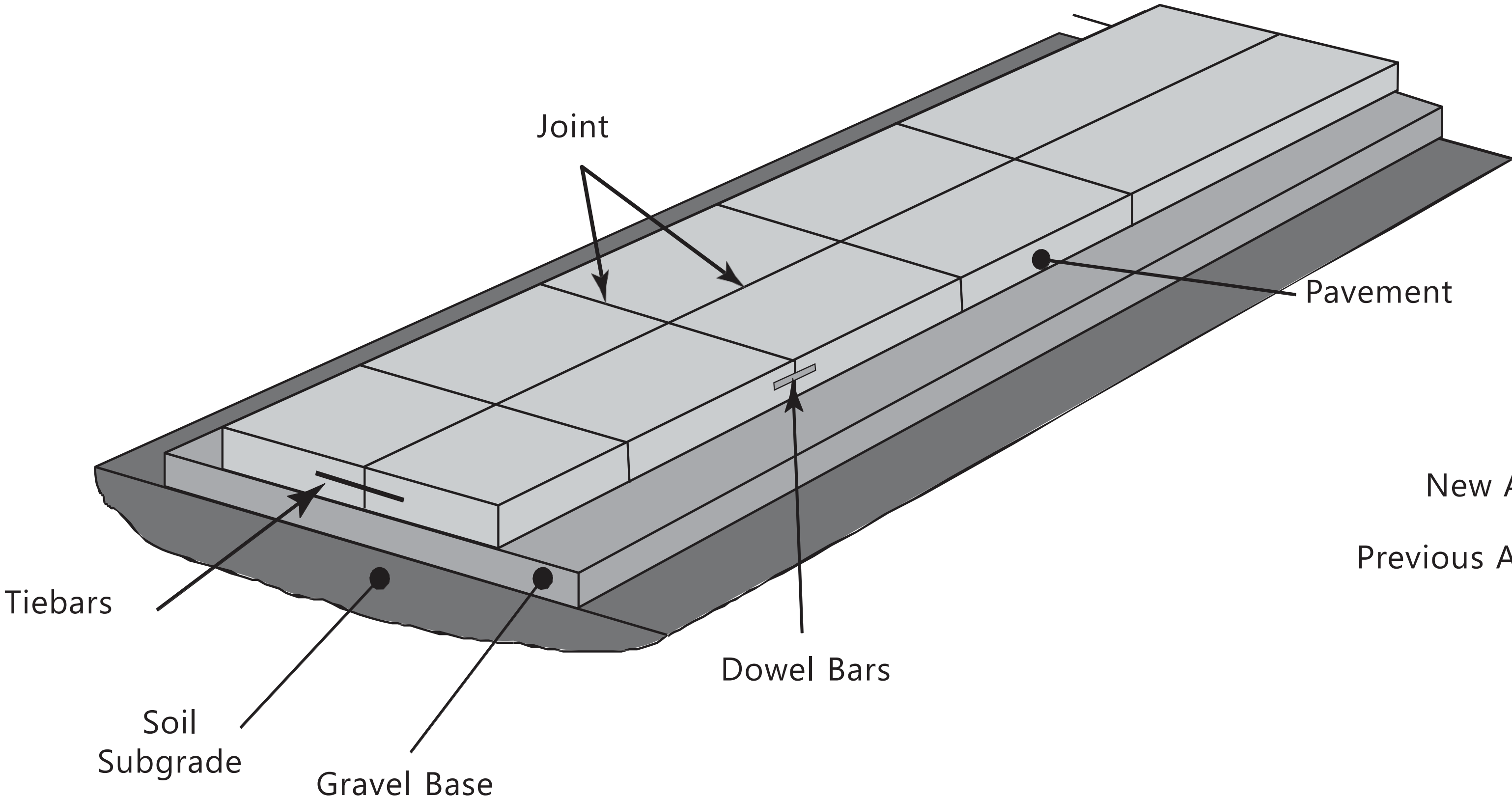

## BASIC PAVING COMPONENTS

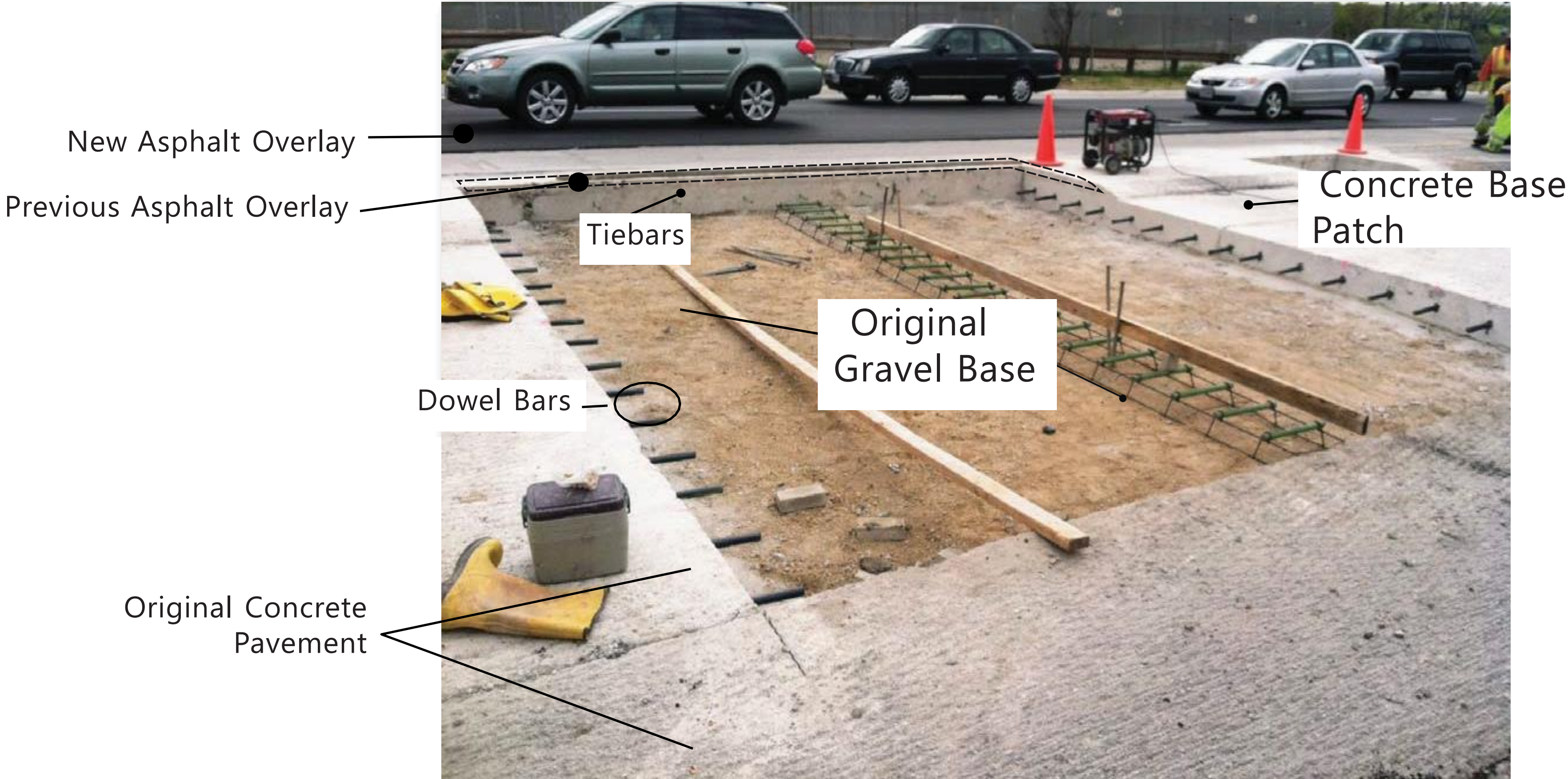

**I-894/I-43/I-41 RESURFACING PROJECT**  
 89TH STREET TO 35TH STREET

**WIS 36 RECONSTRUCTION PROJECT**  
 LOOMIS ROAD BRIDGE OVER I-894





# BRIDGE TERMINOLOGY

There are several types of construction designs for bridges. Most Wisconsin bridges have:

## SIDE VIEW

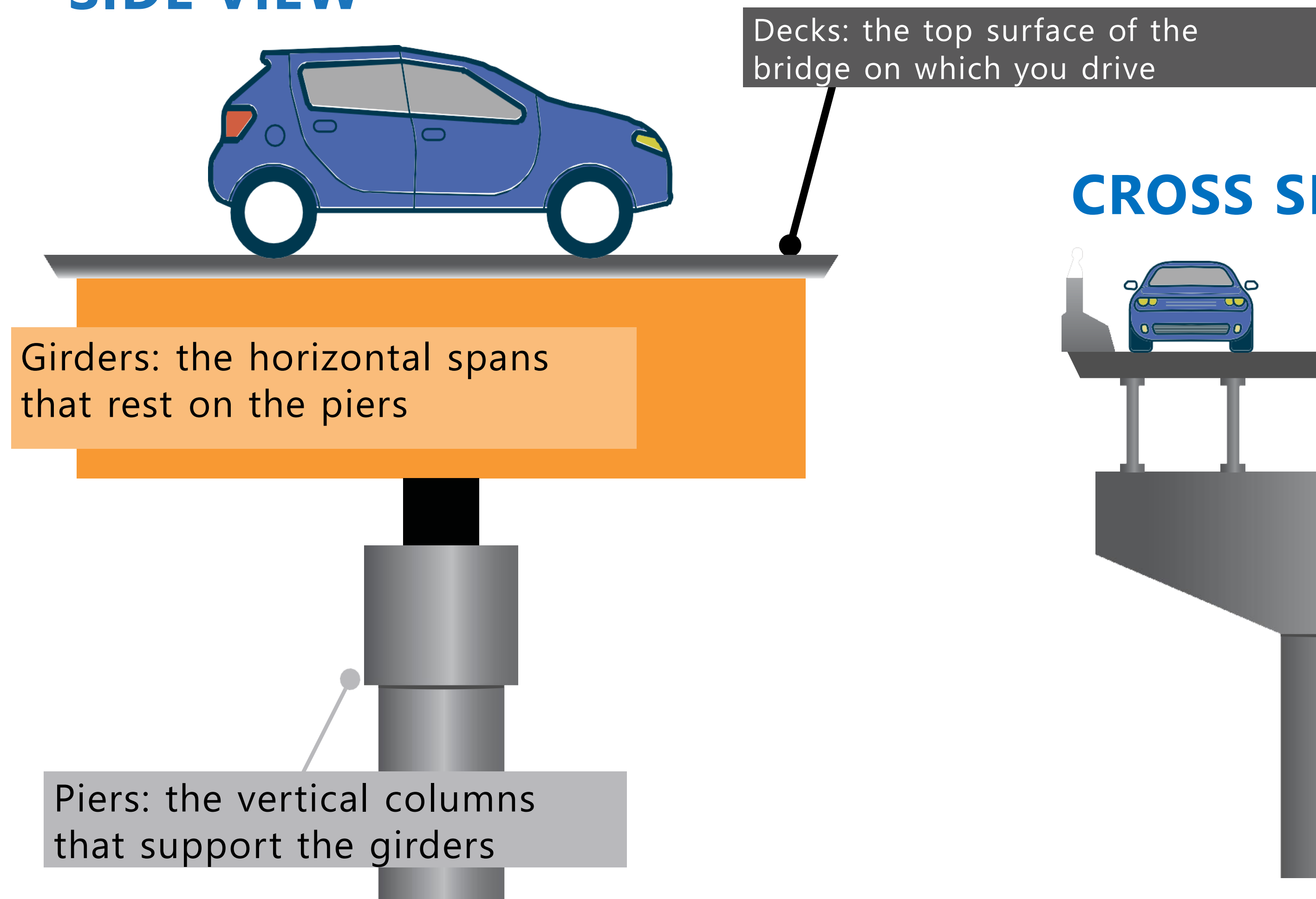

## CROSS SECTION VIEW

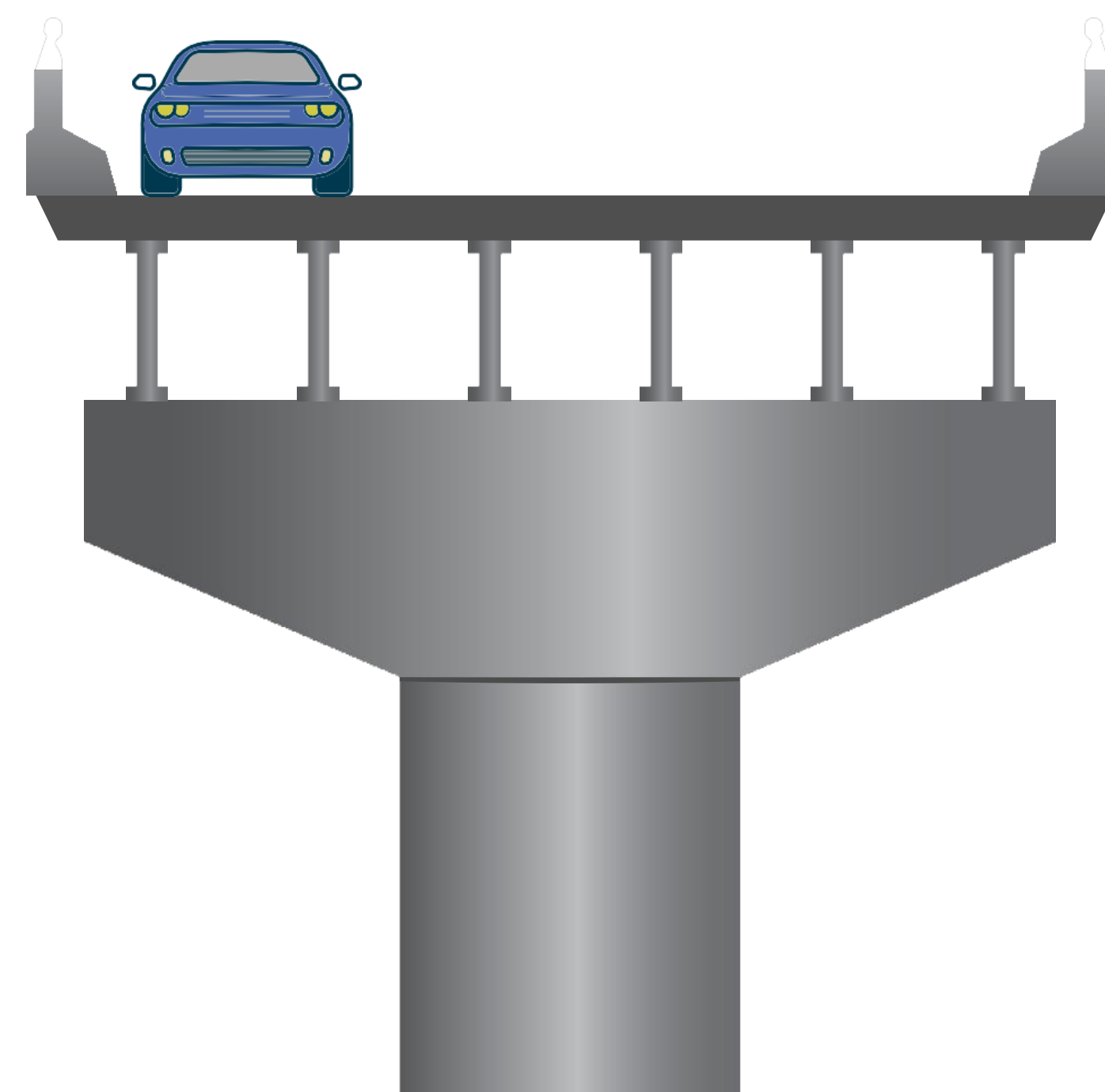

## BRIDGE DECK OVERLAYS

When cracks form in bridge decks, it allows water and salt to come in contact with the rebar, causing the rebar to rust and the concrete to break down. This results in costly repairs and ultimately may require bridge replacement.

Bridge decks can be overlaid to protect the deck and slow degradation. The top layer of the deck can be ground off and replaced with a new overlay surface or seal. This is intended to extend the service life of the bridge.

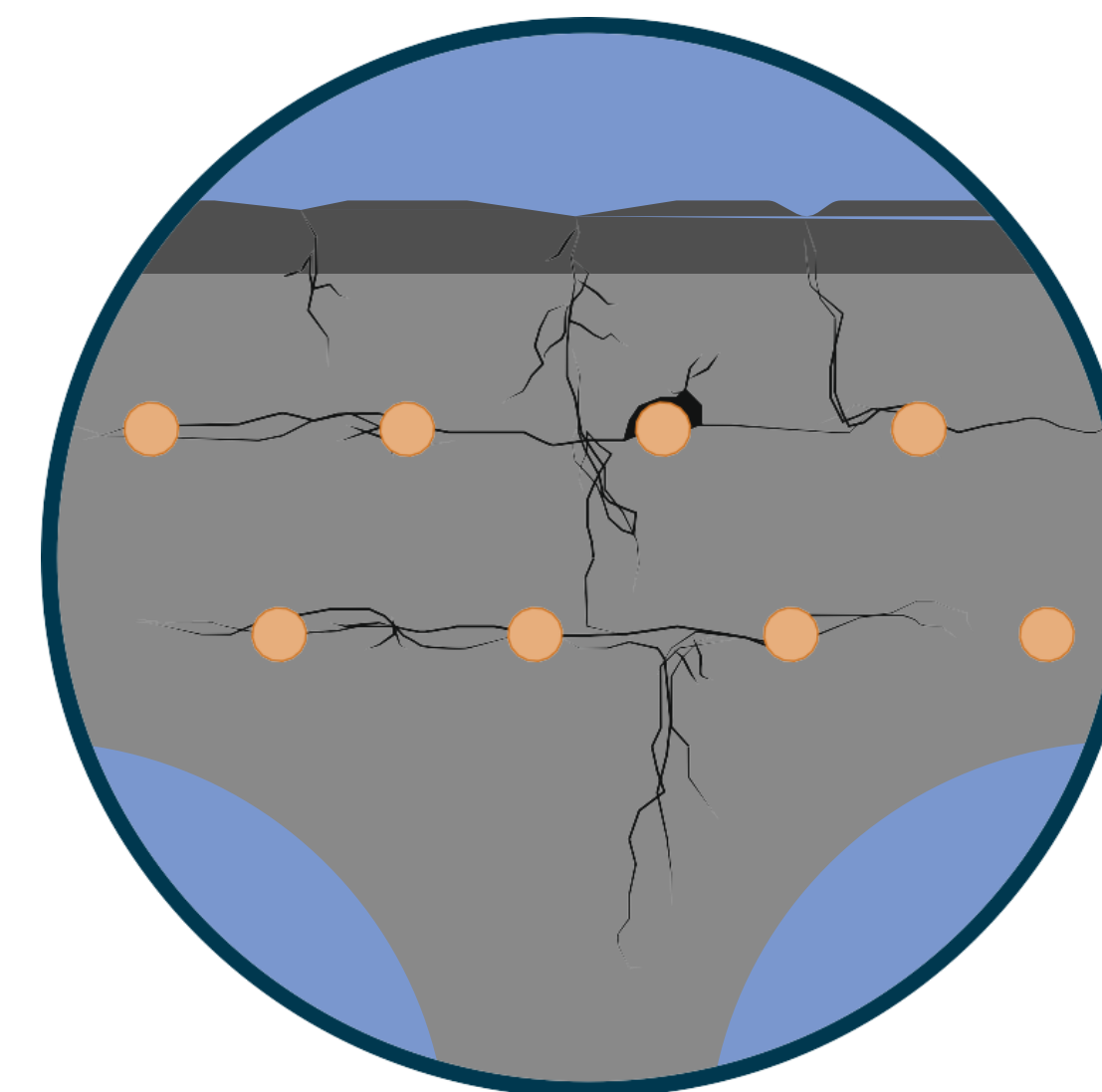

Several types of bridge overlays will be installed as a part of this project.



**I-894/I-43/I-41 RESURFACING PROJECT**  
89TH STREET TO 35TH STREET



**WIS 36 RECONSTRUCTION PROJECT**  
LOOMIS ROAD BRIDGE OVER I-894



# TYPICAL SECTION

## I-894/I-43/I-41 Typical Section of Roadway

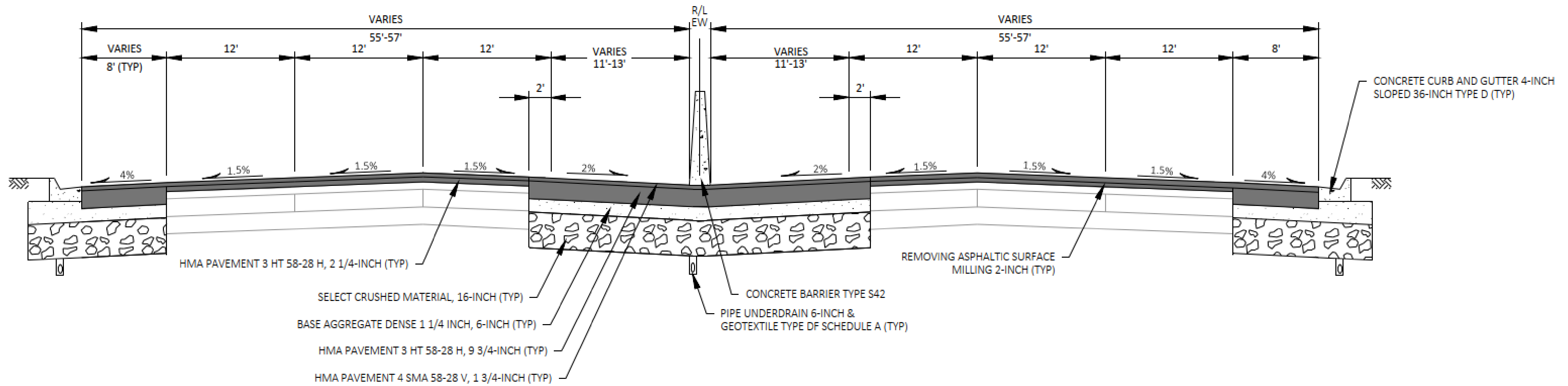

**I-894/I-43/I-41 RESURFACING PROJECT**

89TH STREET TO 35TH STREET

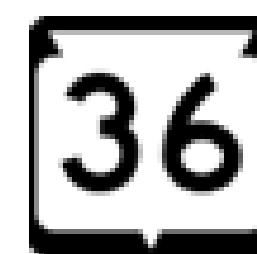

**WIS 36 RECONSTRUCTION PROJECT**

LOOMIS ROAD BRIDGE OVER I-894





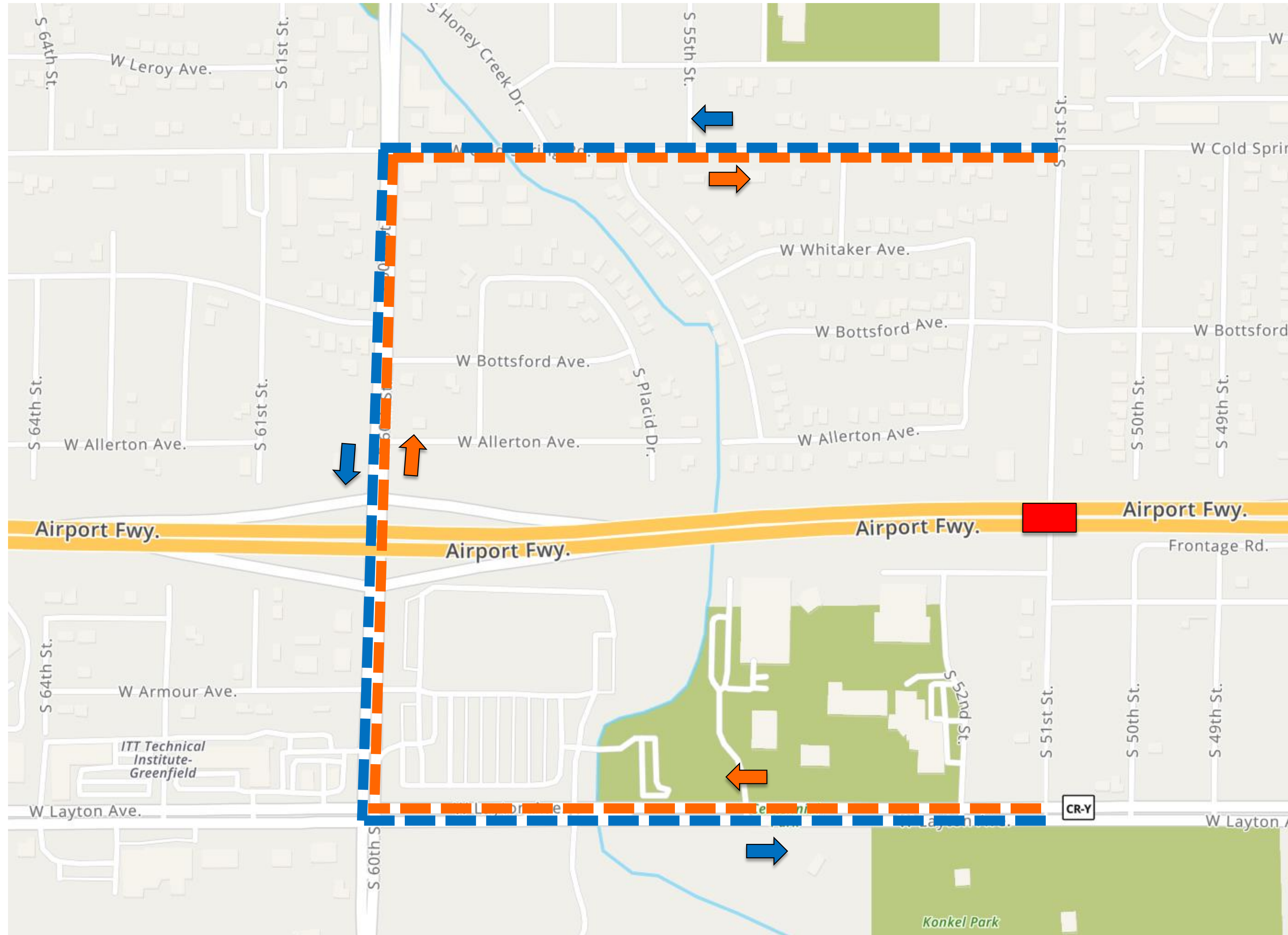

# DETOUR ROUTES



## 51<sup>st</sup> STREET

A full closure of 51<sup>st</sup> Street in both directions (under the freeway) will occur for approximately two weeks this summer, likely in July or August. During the full closure, the freeway bridges will be repainted and rehabilitated. Pedestrian facilities under the bridges will remain open. The signed detour route will use Cold Spring Road, 60<sup>th</sup> Street and Layton Avenue.

## LEGEND

-  51<sup>st</sup> Street Northbound Detour Route
-  51<sup>st</sup> Street Southbound Detour Route
-  Closure Area (Freeway Bridge Work)



**I-894/I-43/I-41 RESURFACING PROJECT**  
89TH STREET TO 35TH STREET

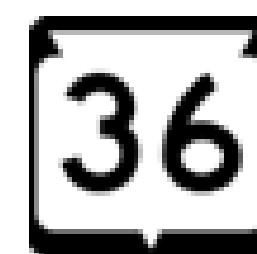

**WIS 36 RECONSTRUCTION PROJECT**  
LOOMIS ROAD BRIDGE OVER I-894





# DETOUR ROUTES

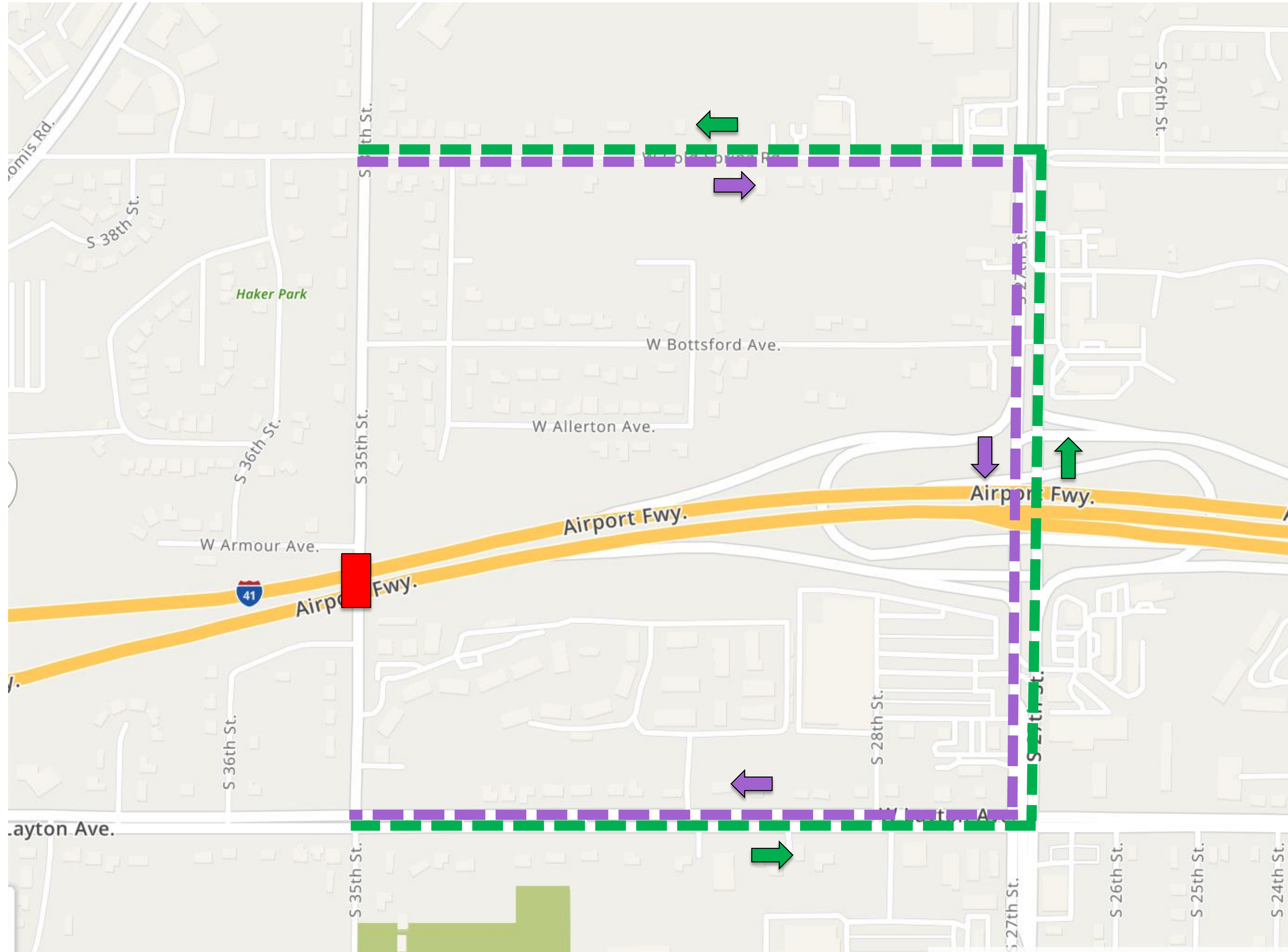

## 35<sup>th</sup> STREET

A full closure of the 35<sup>th</sup> Street bridge over the freeway in both directions will occur for 30 consecutive days in the summer, anticipated to start in later June or early July. During the full closure, the 35<sup>th</sup> Street bridge girders will be repaired. The signed detour route will use Cold Spring Road, 27<sup>th</sup> Street and Layton Avenue.

## LEGEND

- - - 35<sup>th</sup> Street Northbound Detour Route
- - - 35<sup>th</sup> Street Southbound Detour Route
- Closure Area (35<sup>th</sup> Street Bridge Work)



**I-894/I-43/I-41 RESURFACING PROJECT**  
89TH STREET TO 35TH STREET

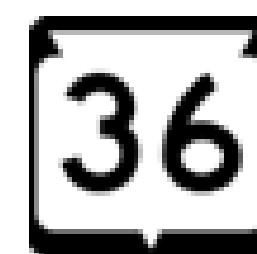

**WIS 36 RECONSTRUCTION PROJECT**  
LOOMIS ROAD BRIDGE OVER I-894

